

well as the limited potential market for specialty harvesters for these minor crops.

Clear interactions exist between the cultivar, cultural practices, a mechanical harvester and several postharvest requirements. As a result, a system-level approach is critical for developing economically viable, highly automated vegetable production systems. Furthermore, improvements in plant architectures and yields and other modifications to crops are required before some vegetables can be machine harvested. Some of the attributes requiring further development include, but are not limited to, better fruit location within the plant structure, more uniform fruit sets, increased mechanical damage resistance, prevention of premature or difficult fruit detachment, and more robust postharvest quality and stability.

The integration of new technologies including DGPS, automatic machine guidance, and computer-based vision systems offers significant performance benefits, and is a substantial component of current vegetable production and harvesting research in the U.S. As costs continue to decrease for these new technologies, commercial adoption will increase.

Literature cited

Arndt, G., W.M. Perry, and R. Rudziewiczski. 1994. Advances in robotized asparagus harvesting, p. 261-266. Proc. 25th Intl. Symp. Industrial Robots.

Arndt, G., R., R. Rudziewiczski, and V.A. Stewart. 1997. On the future of automated selective asparagus harvesting technology. *Computers Electronics Agr.* 16(2):137-145.

Cho, S.I., K.J. An, Y.Y. Kim, and S.J. Chang. 2002. Development of a three-degrees-of-freedom robot for harvesting lettuce using machine vision and fuzzy logic control. *Biosystems Eng.* 82(2):143-149.

Glancey, J.L. 2003. Machine design for vegetable production systems, p. 1105-1115. In: D.R. Heldman (ed.). *The encyclopedia of agricultural, food and biological engineering*. Marcel Dekker, New York.

Glancey, J.L., W.E. Kee, T.L. Wootten, and M.D. Dukes. 2004. Effects of plant architecture on the mechanical recovery of bush-type vegetable crops. ASAE Paper No. 041024. Amer. Soc. Agr. Eng., St. Joseph, Mich.

Glancey, J.L., W.E. Kee, T.L. Wootten, and D.W. Hofstetter. 1998. Feasibility of once-over mechanical harvest of processing squash. ASAE Paper No. 98-1093. Amer. Soc. Agr. Eng., St. Joseph, Mich.

Glancey, J.L., W.E. Kee, T.L. Wootten, M.D. Dukes, and B.C. Postles. 1996. Field losses for mechanically harvested green peas for processing. *J. Veg. Crop Production* 2(1):61-81.

Kahn, B.A., Y. Wu, N.O. Maness, J.B. Solic, and R.W. Whitney. 2003. Densely planted okra for destructive harvest: III. Effects of nitrogen nutrition. *HortScience* 38(7):1370-1373.

Inman, J.W. 2003. Fresh vegetable harvesting. Resource: Engineering and Technology for Sustainable World 10(8):7-8.

Palau, E. and A. Torregrosa. 1997. Mechanical harvesting of paprika peppers in Spain. *J. Agr. Eng. Res.* 66(3):195-201.

Roberson, G.T. 2000. Precision agriculture technology for horticultural crop production. *HortTechnology* 10(3):448-451.

Upadhyaya, S.K., U. Rosa, M. Ehsani, M. Koller, M. Josiah, and T. Shikanai. 1999. Precision farming in a tomato production system. ASAE Paper No. 99-1147. Amer. Soc. Agr. Eng., St. Joseph, Mich.

U.S. Dept. Agr. 2004. Vegetables at a glance: Area, production, value, unit value, trade and per capita use. 25 June 2004. <<http://www.crs.usda.gov/briefing/vegetables/vegpdf/VetAtAGlance.pdf>>.

Vassallo, M., E. Benson, and W.E. Kee. 2002. Evaluation of multispectral images for harvester guidance. ASAE Paper No. 02-1202. Amer. Soc. Agr. Eng., St. Joseph, Mich.

Wall, M.W., S. Walker, A. Wall, E. Hughson, and R. Phillips. 2003. Yield and quality of machine-harvested red chile peppers. *HortTechnology* 13(2):296-302.

Wu, Y., B.A. Kahn, N.O. Maness, J.B. Solic, R.W. Whitney, and K.E. Conway. 2003a. Densely planted okra for destructive harvest: II. Effects on plant architecture. *HortScience* 38(7):1365-1369.

Wu, Y., B.A. Kahn, N.O. Maness, J.B. Solic, R.W. Whitney, and K.E. Conway. 2003b. Densely planted okra for destructive harvest: I. Effects on yield. *HortScience* 38(7):1360-1364.

Engineering and Horticultural Aspects of Robotic Fruit Harvesting: Opportunities and Constraints

T. Burks¹, F. Villegas²,
M. Hannan³, S. Flood³,
B. Sivaraman³,
V. Subramanian³, and J. Sikes³

ADDITIONAL INDEX WORDS. selective harvesting, automated production, machine vision

SUMMARY. Automated solutions for fresh market fruit and vegetable harvesting have been studied by numerous researchers around the world during the past several decades. However, very few developments have been adopted and put into practice. The reasons for this lack of success are due to technical, economic, horticultural, and producer acceptance issues. The solutions to agricultural robotic mechanization problems are multidisciplinary in nature. Although there have been significant technology advances during the past decade, many scientific challenges remain. Viable solutions will require engineers and horticultural scientists who understand crop-specific biological systems and production practices, as well as the machinery, robotics, and controls issues associated with the automated production systems. Focused multidisciplinary teams are needed to address the full range of commodity-specific technical issues involved. Although there will be common technology components, such as machine vision, robotic manipula-

¹PhD, PE, Assistant Professor, University of Florida, 225 Frazier-Rogers Hall, PO Box 110570, Gainesville, FL 32611-0570. To whom reprint requests should be addressed. E-mail: TFBurks@fas.ufl.edu

²Postdoctorate, University of Florida, Agricultural and Biological Engineering Department, Gainesville.

³PhD Candidate, University of Florida, Agricultural and Biological Engineering Department, Gainesville.

Acknowledgments. Research conducted at the University of Florida, Institute of Food and Agricultural Sciences, through funding provided by the Florida Department of Citrus. Special thanks are given to M. Wilder for her help in editing this manuscript. This is a Florida Agricultural Experiment Station Journal Series R-09821.

tion, vehicle guidance, and so on, each application will be specialized, due to the unique nature of the biological system. Collaboration and technology sharing between commodity groups offers the benefit of leveraged research and development dollars and reduced overall development time for multiple commodities. This paper presents an overview of the major horticultural and engineering aspects of robotic mechanization for horticultural crop harvesting systems.

Several horticultural commodity groups around the nation are facing growing global market pressures that threaten their long-term viability. For instance, Brazilian orange (*Citrus sinensis*) growers can produce, process, and ship juice to Florida markets cheaper than can Florida growers. In the event that tariffs are eliminated, numerous horticultural commodities across the nation will not be able to compete in either domestic or international markets with their counterparts in Latin America and Asia. The combination of low commodity prices both domestically and abroad, high labor prices, and low labor productivity presents significant challenges for U.S. agriculture. Several commodity groups, including Florida tomato (*Lycopersicon esculentum*) and orange, California citrus (*Citrus* spp.), New York apple (*Malus × domestica*), and northwestern U.S. deciduous tree fruits recognize that harvesting labor is one of the most crucial challenges to maintaining economic viability for U.S. horticultural crops. According to economic studies, harvesting labor represents over 40% of citrus production cost and will need to be cut by 50% in order to maintain global competitiveness (Brown, 2002).

The potential societal benefits from agricultural robotic mechanization are numerous. By sustaining crucial commodities, the economic infrastructure which supports these industries will be reinvigorated. Rural communities will have new opportunities for better jobs that have less drudgery than traditional manual field labor. Opportunities to improve worker health and safety by automating dangerous operations have significant potential.

The objective of this paper is to present an overview of the major horticultural and engineering aspects

of robotic mechanization for horticultural crop harvesting systems. In order to provide the reader with sufficient breadth of information, this paper is primarily a literature survey and synthesis, which tries to identify the key issues that robotic system developers and horticultural scientists should consider to optimize plant-machine system performance.

Horticultural aspects of robotic harvesting

Robotic solutions for fresh market fruit and vegetable harvesting have been studied by numerous researchers around the world during the past several decades. However, very few developments have been adopted and put into practice. The reasons for this lack of success are due to technical, economic, horticultural, and producer acceptance issues. In industrial automation applications, the robots' environment is designed for optimal performance, eliminating as many variables as possible through careful systems planning. In agricultural settings, environmental and horticultural control can be a significant hurdle to successful automation. Not only must the plant system be designed for successful automation, but the cultural and horticultural practices employed by the producers must often be changed to provide a plant growth environment in which robotic systems can be successful. According to Sarig (1993), "The major problems that must be solved with a robotic picking system include recognizing and locating the fruit, and detaching it according to prescribed criteria, without damaging either the fruit or the tree. In addition, the robotic system needs to be economically sound to warrant its use as an alternative method to hand picking." If the plant growth systems can be modified to improve harvestability, the robotic system will have a much better chance of being successful.

Modifications and improvements of cultural practices for mechanization are continually being made through research and experience (Sims, 1969). In order to have a successful automated/mechanized system, the cultural practices must be designed for the machine and the variety (Davis, 1969). Cultural practices are a critical factor in mechanization of fruit and vegetable production and harvesting. Mechanization of fruit and vegetable

crops requires major design components—machine, variety, and cultural practices. A systems development approach must be followed to insure that all three aspects are considered (Sims, 1969). The major aspects related to cultural practices that affect fruit and vegetable mechanical harvesting include field conditions, plant population and spacing, and plant shape and size. Efficient harvest mechanization cannot be achieved by machine design alone. Establishing favorable field conditions for the harvesting system under development has to be considered before the harvesting system can be effectively developed (Wolf and Alper, 1983).

Peterson et al. (1999) developed a robotic bulk harvesting system for apples. They trained the apple trees using a Y-trellis system and found them to be compatible with the mechanical robotic harvesting. Fruit was trained to grow on the side and lower branches to improve fruit detection and removal. They further suggested that pruning could enhance the harvesting process by removing unproductive branches that block effective harvesting. Further research was suggested to determine the variety and rootstock combinations most compatible with the training and harvesting system.

The concept of designing a grove for optimal economic gain is being considered for citrus production. In the model grove concept, a grove must be designed for the optimal combination of varieties, rootstocks, grove layout, production practices, and harvesting methodologies, which will provide maximum economic yield.

PLANT POPULATION AND SPACING. Harvesting equipment can operate at maximum productivity when the workspace has been organized to minimize inefficient obstacles, standardize fruit presentation, provide sufficient alleyways, and maximize fruit density on uniform growth planes.

Certain tree species and even certain varieties within species have an optimal subsistence area for best fruit production, which provides a proper ratio between the number of leaves needed to produce carbohydrates and other organic compounds, and the number of developing fruits (Monselise and Goldschmidt, 1982). The woody mass—roots, trunk, scaffolds, and branches—supports the tree canopy, but contributes minimally toward fruit development once nutrient uptake and

moisture demands are met. However, the woody mass continues to use the tree's resources to maintain itself, presenting obstructions to robotic harvesting. Ben-Tal (1983) suggested that maximum yield per unit area would be achieved by a large number of relatively small trees, suggesting that smaller robotic systems may actually provide a better economic return.

Scalability of robotic systems is an important economic factor, which impacts the design of the plant growth system. The productivity of large multiple-arm systems vs. smaller, more agile, human-like robots is an important economic question. Large equipment systems require wide row spacings while smaller systems can work in a more confined grove configuration. Optimally, the fruit should be grown in a hedge row configuration where the plants produce a maximum number of fruits over the surface area (Ben-Tal, 1983). This suggests that the trees or plants be grown at a close spacing so that the growth plane is uniform, with minimal scalloping of the hedge between plants.

PLANT SHAPE AND SIZE. The ideal configuration for efficient robotic harvesting would be a vertical or slightly inclined hedge wall, 10 to 12 ft (3.0 to 3.7 m) tall, that is relatively uniform, smooth, and continuous from start to row end. The fruit would be located on the canopy surface with minimal occlusion. In reality this would not be the case, but the example provides some insight into what a robot would need in order to maintain fast harvest cycle times and maximum fruit removal. Deviations from the ideal will cost removal efficiency and cycle time performance.

Orchards should have uniform plant sizes and predictable shapes for efficient robotic harvesting (Cargill, 1983). Standardization of tree sizes would significantly improve harvesting throughput and thus economic benefit. These standard sizes should consider tree height, tree thickness, tree shape, and tree spacing within and between rows so that the robotic equipment can maintain continuous harvesting, with minimal idle harvest time when traveling between trees. A number of these features are designed into the grove at planting, while others must be maintained mechanically. A common modern approach for maintaining both tree size and shape is mechanical

pruning. The trees can be pruned to the desired shape before fruit set and allowed to grow during the remainder of the year. In some limited cases, severe pruning is being tested. Under this practice, alternating sides of the tree are pruned each year and allowed to set fallow, while the other side of the tree produces the current year's crop. When the canopy returns the following year, the woody mass is covered by the new growth and a relatively uniform vertical wall is achieved. Impact of annual fruit yield has not been reported on this technique to date.

Experiments conducted on apples demonstrated that tree shape contributes toward the suitability of mechanical harvesting (Zocca, 1983). Modifications to cultural practices for growing and harvesting fruit are important for successful mechanical harvesting. A mechanized pruner was developed that not only reduced the labor required for pruning, but also properly shaped the hedgerow for maximum harvesting efficiency of erect cane fruits (Morris, 1983).

Ben-Tal (1983) pointed out several problems that can arise when an orchard is prepared through pruning for a specific kind of equipment, such as reduced yield, fruit quality, and the number of years of production. Additional issues, such as canopy light exposure and maximum height of a tree for proper spraying, pruning, etc., should be considered. The question of plant geometry and its relationship to productivity needs to be thoroughly examined (Rohrbach, 1983).

TREE GENETICS FOR OPTIMAL HARVESTING. Plant breeders developing new varieties of fruit must consider if the variety will be accepted at market and if it will be durable under machine handling. Attractive appearance and long shelf life are imperative in the fresh market. Varieties must be resistant to bruising, cracking, and rupturing during machine handling. The fruit must be relatively easy to remove from the plant and the peduncle must remain attached (Davis, 1969; Lapushner et al., 1983).

In addition to fruit-related issues, there are a number of tree factors that can be improved genetically that can enhance robotic harvestability. Two major obstacles impede efficient robotic harvesting: 1) locating fruit occluded by the leaf canopy; and 2) harvesting fruit located in the tree or

plant interior. In both cases, a plant system that presented the majority of the fruit at the canopy surface would improve harvestability. There are two possible solutions. The first would suggest a thin leaf canopy so that the detection systems could more easily view the plant interior, and the second suggests a dense canopy that might force more fruit to grow at the surface. The two strategies seem to be in conflict under normal tree behavior. Sparsely leafed trees tend to have more interior fruit, which reduces fruit accessibility, while densely leafed trees will make it more difficult to sense the interior fruit. A tree which is naturally fruited at the limb extremities with minimal interior fruit might resolve this problem.

Another primary concern is canopy uniformity. Factors affecting uniformity in emergence, stand, growth, and maturity must be clearly understood in order to develop viable plant systems for mechanical harvesting (Davis, 1969). Cultural practices have been discussed that could produce a hedge-row system. However, trees that require severe hedging to maintain their shape often develop woody structures near the surface, which could be an obstacle to robotically harvesting interior fruit. A tree that grew to an appropriate mature height and shape and then maintained its size with either minimal hedging or woody mass build-up would be ideal.

Several plant breeding projects have contributed favorably to mechanical harvesting. Peach (*Prunus persica*) breeders increased fruit harvest by releasing varieties with varying maturities, effectively doubling or tripling the length of the peach season in many production areas (Carew, 1969). Dwarfing rootstocks in combination with apple varieties have provided size control of apple trees. Plant improvement through breeding can modify crop characteristics and assist in the introduction of mechanical harvesting systems (Carew, 1969).

Engineering design aspects of robotic harvesting

Robotic systems developers from the U.S., Europe, Israel, and Japan have conducted independent research and development on harvesting systems for apples and citrus achieving harvesting efficiencies of 75%. These low levels of performance were attributed to

poor fruit identification and the inability to negotiate natural obstacles inside the tree canopy (Sarig, 1993). Harvesting cycle times for citrus were estimated at 2 s/fruit for a two-arm machine (or 4 s/fruit for a single-arm machine). Cycle time should be higher for apples due to a more open canopy (Sarig, 1993). These levels of harvesting performance and economic return prevented producer acceptance of robotic harvesting.

PHYSICAL PROPERTIES AND FRUIT REMOVAL. A robotic harvester must be able to quickly remove the fruit without damaging the fruit or the tree. An integral part of the harvester is the end-effector, which is a tool or device attached to the end of the manipulator that grabs and removes the fruit from the tree. Because of its direct interaction with the fruit and tree structure, it must be designed with the specific physical properties of the commodity to be harvested in mind.

There are several ways that a robot might damage the fruit or tree: 1) end-effector applying excessive positive or negative pressure or force to the fruit during pick and place operations; 2) inappropriate stem separation techniques for the type of fruit; 3) fruit damage during retraction from the tree canopy or conveyance to bulk storage; or 4) manipulator contact with the tree structure. Fruit damage may not be physically evident immediately, yet bruising, scratches, cuts, or punctures will result in decreased shelf life. A properly designed end-effector will attempt to minimize fruit damage.

The fruit removal technique employed is typically the largest cause of fruit injury. In the case of oranges, the fruit must be harvested with the calyx intact and the stem removed flush with the calyx. If the peel is torn away from the calyx, the resulting fruit is unusable for the fresh fruit market due to contamination and reduced shelf life. This condition is referred to as "plugging." If a long stem remains on the fruit, the packer will either reject the fruit or require stem removal post-harvest. Fornes et al. (1994) reported citrus detachment conditions for fruit removed using a prototype vacuum-grip rotational-separation end-effector. Fruit detachment conditions varied with maturity for the three citrus varieties reported: 'Clausellina' (*Citrus unshiu*), 'Clemenules' (*C. unshiu*), and 'Navelina' (*C. sinensis*). The mandarin

varieties (*C. unshiu*) tended to be more susceptible to undesirable detachment conditions than other citrus varieties. 'Clausellina' exhibited 8% to 19% calyxless conditions, depending on fruit maturity, while 'Navelina' was relatively constant at 2% to 3% calyxless. Fornes et al. (1994) also reported that detachment method and damage varied with rotational speed for the same three varieties.

Juste et al. (1988) researched the detachment forces of 'Salustiana' (*C. sinensis*) and 'Washington' navel oranges (*C. sinensis*). 'Salustiana' was found to have a detachment force 73.1 ± 0.6 N (16.43 ± 0.13 lbf) and 'Washington' was found to have a detachment force of 54.4 ± 4.7 N (12.23 ± 1.06 lbf). The detachment force of 'Washington' was found to substantially increase with an increase in maturity. All of these forces were measured along the stem axis. Fornes et al. (1994) also researched detachment forces on 'Clausellina' and 'Clemenules' mandarins, and 'Navelina' oranges. Detachment forces for all three varieties were found to decrease as maturity increased.

Juste et al. (1988) measured torsional detachment by counting the number of turns required to detach the fruit. 'Salustiana' displayed an average twist of 2.48 ± 0.12 revolutions and 'Washington' displayed an average twist of 2.36 ± 0.11 revolutions. The maximum twist was 4.75 revolutions for both varieties. Approximately 60% of 'Salustiana' still had a stem, which was on average 3.82 ± 0.36 mm (0.150 ± 0.014 inch) in length. Approximately 78% of 'Washington' navel oranges still had a stem, which was on average 6.33 ± 1.14 mm (0.249 ± 0.044 inch) in length. Rabatel et al. (1995) stated that a stem length of 5.0 mm (0.20 inch) or less was desirable. It should be noted that in these tests the calyx remained intact on the torsional detachments, but 70% of the direct pulling detachments had calyx separation or displayed "plugging." Coppock (1984) observed a near 50% reduction in pulling detachment force when the force was applied at a 90° angle from the stem axis for 'Valencia' oranges (*C. sinensis*). This reduction in detachment force might decrease the amount of plugging exhibited.

The rind of oranges makes them one of the more durable fruits, in contrast with more delicate-skinned products, such as tomatoes. They are

still, however, susceptible to injury. Injury is more prevalent in less mature oranges, as was found by Juste et al. (1988). The resistance to pressure was found to stabilize as the oranges matured at around 343.2 kPa (49.78 psi) for 'Salustiana' and 441.3 kPa (64.01 psi) for 'Washington' using a circular surface area of 1.1 cm² (0.17 inch²). Rind penetration tests were also performed using a 4.7-mm-diameter (0.19 inch) punch. Penetration force was found to be 28.9 N (6.50 lbf) for 'Salustiana' oranges and 26.6 N (5.98 lbf) for 'Washington' navel oranges.

When manually harvesting oranges the fruit is detached using one of three methods, depending on the variety and cultural practice. The laborer can use a set of clippers to detach the fruit, usually leaving as short a stem as possible. Secondly, the laborer can lift the fruit so that the stem axis is rotated 90° and then pull down so that the force is perpendicular to the stem axis. Lastly, the laborer can add a twisting motion to the second method. Although the end-effector does not necessarily have to follow one of these methods, an understanding of manual procedures gives insight into some of the potential methods.

The first type of robotic orange harvesting end effectors that has been developed is the cutting end-effector. Several cutting end-effector designs have been developed as described in Ito (1990), Sarig (1993), Pool and Harrell (1991), and Bedford et al. (1998). This method is prevalent in several agricultural applications since it produces the least amount of stress on the actual fruit. The basic premise is to first capture the fruit using a suction cup or gripper, and then use a cutting device to sever the stem that is holding the fruit onto the tree. This can either be done blindly by swinging a blade around the outer edge or by detecting the stem's location and cutting it with a scissor device. The stem's location can either be detected through machine vision or through force/torque sensors.

In the blind system a blade passes around the encased fruit to sever the stem without damaging adjacent fruit or the tree. The blade must be large enough to encircle the fruit, and must maintain sharpness to achieve a clean cut. The scissor method reduces the chance of fruit damage but is sub-

stantially more complex, requiring a larger end-effector, more sensors, and more time.

The second type of end-effector is the pull and cut end-effector. This method was proposed by Pool and Harrell (1991). In this method, the fruit is grasped either through suction or a type of collection sock. The stem is severed as the end-effector retracts. This method disturbs the surrounding limb structure, making subsequent harvesting more difficult since the fruit is in motion, and still has some of the limitations of the cutting end effectors previously mentioned.

The third type of end-effector design is the twisting method. This method was suggested by Juste et al. (1998) and Rabatel et al. (1995) to be the most promising of the three. This involves twisting the fruit, preferably perpendicular to its attachment axis, until the stem is severed. Twisting the fruit in this manner reduces the amount of disturbance to the tree and thus to the surrounding fruit. Twisting involves the least amount of force of the three methods and has the lowest plugging rate. Like the other two types, fruit size is a consideration here as well. Generally, the twisting action is achieved by use of a rotating suction cup. This cup must be of the right size to create a good seal while still providing enough force to keep the orange from slipping. One of the major advantages of this method is that there is a large flexibility in the angle of approach. Except at the stem, the cup can attach to any part of the fruit.

Tutle (1985) suggested an approach that combined the twisting and pulling approach in U.S. Patent 4,532,757. The end-effector design selected for a given application should be developed in conjunction with the manipulator, sensors, and control development to optimize the capabilities of the harvester.

MACHINE VISION AND SENSING TECHNOLOGIES. According to Sarig (1993), "While major progress has been made with the identification of fruit on the tree and determination of its location, only 85% of the total fruits on the tree are claimed to be identified. Variability in lighting conditions and obscurity of fruits because of leaf and branch coverage (especially in citrus trees), require further development of identification techniques, or major changes in tree shape."

In robotic fruit harvesting systems, machine vision has become one of the most popular sensing systems for fruit identification. With the advent of color cameras, differences between leaf canopy and mature fruit can be discriminated. The vision system is able to determine either two-dimensional (2D) or three-dimensional (3D) position in the canopy, depending on the type of system employed. However, the process of separating the desirable fruit from other objects, such as leaves, branches, and unripe fruit, is very difficult due to the large amount of information that must be processed. This is a difficult task even with today's relatively high-speed computers. To put this into perspective, one 640 × 480-pixel color image has almost one million data points, and a standard video camera runs at 30 frames per second, resulting in 30 million data points to process every second.

Machine vision systems commonly applied to agricultural applications acquire reflectance, transmittance, or fluorescence images of the object under ultraviolet, visible, or infrared illumination. A basic machine vision system includes a camera, optics, lighting, a data acquisition system, and a processor. Fujiura (1997) developed robots having a 3D machine vision system for crop recognition. The vision system illuminated the crop using red and infrared laser diodes and used three position-sensitive devices to detect the reflected light. The sensors selected were suitable for agricultural robots that are required to measure the 3D shape and size of targets within a limited measuring range. Jimenez et al. (2000) developed a laser-based vision system for automatic fruit recognition to be applied to an orange-harvesting robot. The machine vision system was based on an infrared laser range-finder sensor that provides range and reflectance images and was designed to detect spherical objects in non-structured environments. The sensor output included 3D position, radius, and surface reflectivity of each spherical target, and had good classification performance.

Plebe and Grasso (2001) presented a color-based algorithm for detecting oranges and determining the target centers. They also applied stereo imaging to these processed images to determine the range to the detected fruit. They presented results from 50

images that contained 673 oranges that were taken at an actual orange grove. Their algorithm correctly identified 87% of the oranges, while 15% of the detected regions were incorrectly classified as oranges. Their approach had difficulty with both brightly and poorly lit oranges, brightly lit leaves, and certain types of occlusion. Bulanon et al. (2001) presented an algorithm that used a 240 × 240 pixel color image to detect apples. The apples were detected by thresholding the image using both the red color difference and luminance values. It was determined that the red color difference values were much more effective at detecting the apples than the luminance values.

There are three major problem areas associated with the use of machine vision-based sensing: 1) partial and totally occluded fruit are difficult to accurately detect; 2) light variability can result in low detection rates of actual fruit as well as high levels of false detections; and 3) the computational time required to process images as influences real-time control.

Numerous other sensors are commonly employed in robotic harvesting systems, such as ultrasonic range, laser range, capacitive proximity, light emitting diode (LED) range, and so on. It is not likely that a single sensor will solve the complete sensing problem, but several sensors will need to be integrated together to form a complete system.

ROBOTIC MANIPULATION AND CONTROL. The kinematic and geometric description of a robotic manipulator is one of the key tasks in building a robotic system to work, especially in unstructured environments. Harvesting of fruits (orange, apple, etc.) is highly unstructured and the robotic arm should be flexible enough to adapt to changes in the environment. Various geometric coordinate configurations used in industrial applications are available: cartesian, cylindrical, spherical, articulated, and redundant.

In a 1968 review of mechanical citrus-harvesting systems (Schertz and Brown, 1968), the basic principles for utilizing robots to pick fruits were laid out. The earliest laboratory prototype was an apple harvester (Parrish and Goksel, 1997) consisting of a simple arm with a pan-and-tilt mechanism and a touch sensor in place of an end-effector, which made contact with modeled fruit.

The first field prototype for harvesting apples was developed in France (Grand D'Esnon, 1985). The mechanical system consisted of a telescopic arm that moved up and down in a vertical framework. The arm was mounted on a barrel that could rotate horizontally. In 1986, a new prototype (MAGALI) was built (Grand D'Esnon et al., 1987) that used a spherical manipulator servoed by a camera set at the center of the rotation axes. Figure 1 shows the spherical manipulator that can execute a pantographic prismatic movement (only rotational joints) along with two rotations.

In 1986, the University of Florida, along with other collaborators, initiated a program to develop a robotic system for citrus harvesting (Harrell et al., 1988). The outcome of this research was a 3-degree of freedom (DOF) manipulator actuated with servo-hydraulic drives. Joints 0 and 1 were revolute and joint 2 was prismatic. This geometry was characteristic of a spherical coordinate robot (Fig. 2). The feasibility of a robotic citrus harvester was ascertained by this research work.

The French-Spanish Eureka project (Rabatel et al., 1995), started in 1991, was based on the feasibility study done at the University of Florida. The proposed robotic system had a dual harvesting arm configuration to achieve greatest economic return; however, the prototype consisted of only one harvesting arm. The arm had two modules, an elevating arm and a picking arm. The picking arm was of a pantographic structure rather than a linear structure.

The elevating arm supported the picking arm and the associated camera. The elevating arm was equipped with a lateral DOF to avoid collision with the picking arm with the vegetation, while acting as a fruit conveyor as well.

Several manipulator architectures have been attempted for fruit harvesting. Of these, the articulated joint (6 DOF) seems to work the best, since it closely resembles a human arm. In order to avoid obstacles and to harvest interior canopy fruit, the optimal configuration for a robotic harvester may require more degrees of freedom than a standard articulated joint.

AUTONOMOUS VEHICLE GUIDANCE. Autonomous vehicles are being developed for several applications, including agricultural vehicles. The major advantages are precision and

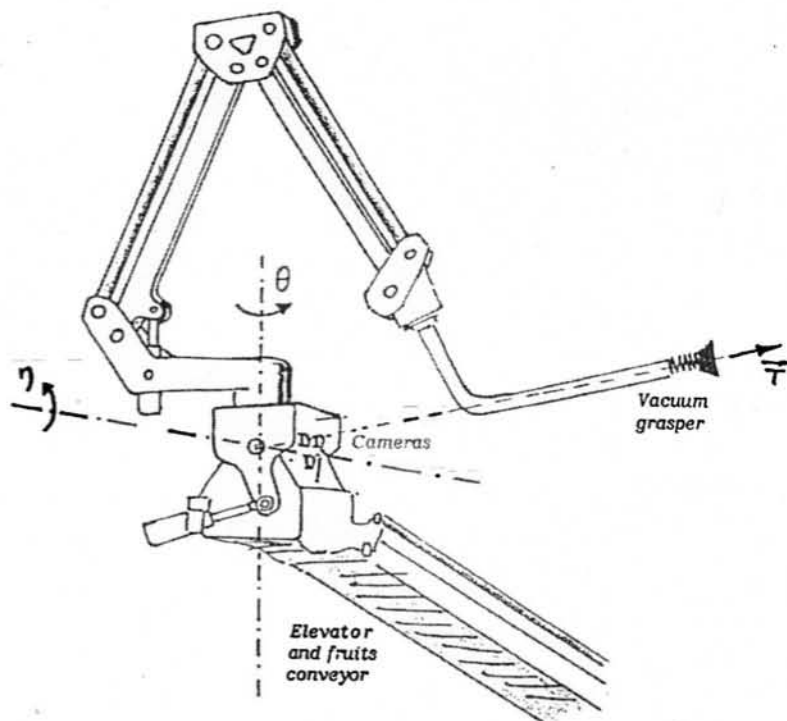

Fig. 1. MAGALI apple-picking arm developed by Grand D'Esnon et al. (1987).

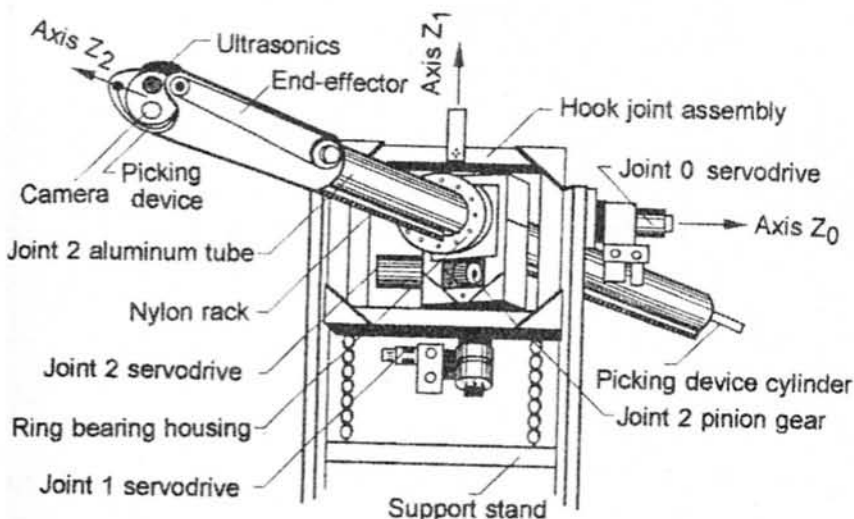

Fig. 2. Citrus-picking robot developed by Harrell et al. (1988).

reduced burden for the operator. Vehicle position, heading, steering effort, and speed with respect to the desired path are the most important issues that must be considered. Global positioning systems (GPS) in combination with inertial navigation systems have been widely used as positioning and heading sensors in traditional field agriculture application. Both realtime kinematic GPS (RTKGPS) and realtime differential GPS (DGPS) have been tested

with success, based on the degree of accuracy required in the navigation system. There is a tradeoff between accuracy and cost in the selection of DGPS and RTKGPS, with the latter being more accurate and expensive. RTKGPS has been giving very accurate results (Benson et al., 2001; Nagasaka et al., 2002; Noguchi et al., 2002). Gyros have been widely used for inclination measurement (Mizushima et al., 2002). Fiberoptic gyro (FOG) has

given the best performance (Nagasaka et al., 2002). At present, gyros and inclinometers are available together as inertial measurement units (IMU) for pitch, roll and yaw, and linear velocity measurements. With the combination of RTKGPS and FOG, accuracy of ± 5 cm (2.0 inches) has been achieved (Noguchi et al., 2002). GPS cannot be used alone for positioning in citrus applications, as it gives errors when the vehicle moves under tree canopies.

In addition to sensing global positions, the vehicle must be able to detect local obstacles that may impede the path. Several sensing technologies have been explored for this task. Ultrasonic sensors can map tree canopies while traveling at speeds of $1.8 \text{ m}\cdot\text{s}^{-1}$ ($5.91 \text{ ft}\cdot\text{s}^{-1}$); measurement accuracy is better at lower speeds (Iida and Burks, 2002). The development of machine vision guidance techniques has become a very attractive sensing alternative, especially when combined with other proximity-based sensors (Benson et al., 2001; Zhang et al., 1999). They have proven to be reliable in several row-crop applications, but have not performed well in sparsely populated crops. Their reliability reduces with low lighting, shadows, dust, and fog. Benson et al. (2001) overcame this by using artificial lighting. Laser radar has been used for ranging and obstacle avoidance. It has higher resolution than ultrasonic sensing, and requires fewer computations than vision. Its performance degrades with dust and rain like vision and it is costlier than ultrasound. It provides planar data of the path, but can generate 3D by rotating the laser source to give a 3D view. O'Connor et al. (1995) found that sensor data is noisy, and can be filtered using Kalman filters to obtain robust sensor fusion.

Steering control is a major factor for accurate guidance. PID control (proportional, integral, derivative) has given satisfactory performance (Zhang et al., 1999). Neural networks have the inherent disadvantage of learning only what the driver does, so they are not robust. Behavior-based control is a new development that has been successfully used in small mobile robots. A behavior-based system in combination with a real-time control system (RTCS) is expected to do well in vehicle guidance. Fuzzy control has recently been tried, with results comparable with PID (Benson et al., 2001). Senoo et

al. (1992) pointed out that the fuzzy controller could achieve better tracking performance than the PI controller. It has wider adaptability to all kinds of inputs. Qiu et al. (2001) verified that the fuzzy steering control provided a prompt and accurate steering rate control on the tractor. Kodagoda et al. (2002) found fuzzy control to be better than PID for longitudinal control. PID was also found to have large chatter, high saturation. A combination of fuzzy and PID control holds significant promise (Benson et al., 2001). Efficient guidance can be achieved using a fuzzy-PID control system with vision, laser radar and IMU as sensors.

Results and discussion

In Summer 2001, the Florida Department of Citrus began an investigation into the potential for using robotics to harvest citrus. Current mass harvesting programs have proven viable for process citrus, but cannot be used for fresh fruit markets and remain questionable for late season 'Valencia', pending abscission chemical development and approval. A fact-finding team evaluated past horticultural robotics efforts, and talked to experts in robotics, agricultural mechanization, horticulture, and economics to determine if there had been sufficient advances in technology and changes in the economic potential for robotic harvesting to suggest that a renewed effort was warranted. The consensus opinion of a Forum on Robotic Citrus Harvesting, held in Apr. 2002, was that there was an urgent need for harvesting solutions for the fresh fruit market, that significant long-term financial commitment would be required, and although it is a difficult problem, enough technical progress has been made in the past decade to warrant a new robotics program.

During the past two decades, since the beginnings of research in agricultural robotics, there have been numerous technological advances. The speed of computers has increased exponentially over the last 10 years. Manipulator technologies have improved so that current manipulators are faster and more dexterous. Machine vision and other sensing technologies, along with image and signal processing technologies, have greatly advanced. Our understanding of horticultural practices and their impact on harvestability has greatly improved. However,

there are still major technological challenges that need to be addressed, such as locating occluded fruit, reaching the interior canopy, maintaining high cycle rates in difficult harvesting conditions, cost affordability, and maintainability of high-tech equipment.

The current citrus robotics development initiative, which is being led by the University of Florida, is seen as a multidisciplinary effort where horticulturalists, economists, and agricultural, mechanical, and electrical engineers are working together to solve some of the complex problems mentioned previously. From a horticultural perspective, research has begun to develop special orange varieties, which may be more favorable toward robotic harvesting. Additionally, research is beginning on the development of a model grove, which will attempt to optimize the grove design and cultural practices for mechanical/robotic harvesting and maximum economic potential. From an economic standpoint, studies are proposed that will evaluate the production system for optimum economic return on investment. The potential labor productivity gains, projected capital equipment cost, harvesting efficiency, value added benefits, and long-term yield impacts of robotic systems will be a few of the factors that will be considered in evaluating the economic potential. In terms of engineering development issues, the primary thrusts will be in the end-effector, manipulator system, sensing technology, material handling, vehicle guidance, and machine intelligence development.

There is a growing interest among researchers working in other tree fruit industries, along with their growers, to pursue automation solutions to reduce the increasing disparity between U.S. production labor cost and those of developing countries. However, it is clear that novel approaches need to be taken to solve robotics technology problems, as well as the manufacturing and maintenance challenges that will surface as high-tech equipment systems are implemented in harsh agricultural environments. These challenges will require a high level of cooperation among engineers, researchers, industry, and growers to insure that these new systems will be able to meet their design objectives. An additional major issue is safety, since agriculture has been a notoriously dangerous workplace. Thoughtful design and appropriate

industry standards will be required to build safety devices into the automated systems that will protect operators and casual observers.

Some expected outcomes are the creation of new jobs associated with the manufacture, operation, and service of machinery and instrumentation; improvement of working conditions, and ability of laborers to become more skilled; and elimination of monotonous and onerous tasks, such as heavy lifting, digging, handling of sharp objects, and repetitive tasks.

Initial optimistic estimates have suggested that a 7- to 10-year multi-million dollar program will be required to bring forth a market-ready citrus harvesting system. It is recognized that significant federal funding will be required to sustain the program for the duration of the development process. Even with major federal research dollars, there is a degree of uncertainty regarding our ability to overcome all technological barriers to high-speed and high-efficiency robotic harvesting. The questions still remain of whether or not these new systems will be accepted by growers and provide an adequate return on investment. If not, these robotics development efforts may meet the same fate as the ones of the 20th century. One major factor looms on the horizon: most major automation and mechanization efforts have been driven by high labor cost and/or inadequate labor supply, both of which could become reality.

Conclusions

The solutions to agricultural robotic mechanization problems are multidisciplinary in nature. Although there have been significant technology advances, many scientific challenges remain. Viable solutions will require engineers and horticultural scientists who understand crop-specific biological systems and production practices, as well as the machinery, robotics, and controls issues associated with automated production systems. Clearly focused multidisciplinary teams are needed to address the full range of commodity-specific technical issues involved. Although there will be common technology components, such as machine vision, robotic manipulation, vehicle guidance, and so on, each application will be specialized due to the unique nature of the biological system. However, collaboration and technol-

ogy sharing between commodity groups will offer the benefit of leveraged research and development dollars and reduced overall development time for multiple commodities.

Literature cited

Bedford, R. Ceres, J.L. Pons, A.R. Jimenez, J.M. Martin, and L. Calderon. 1998. Design and implementation of an aided fruit-harvesting robot (Agribot). *Ind. Robot* 25(5):337-346.

Benson, E.R., J.F. Reid, and Q. Zhang. 2001. Machine vision based steering system for agricultural combines. *Amer. Soc. Agr. Eng. Paper No. 01-1159*.

Ben-Tal, Y. 1983. Horticultural aspects of mechanical fruit harvesting. *Proc. Intl. Symp. on Fruit, Nut, and Veg. Harvesting Mechanization. Amer. Soc. Agr. Eng. SP-5:372-375*.

Brown, G.K. 2002. Mechanical harvesting systems for the Florida citrus juice industry. *Amer. Soc. Agr. Eng. Paper No. 021108*.

Bulanon, D.M., Kataoka, T., Zhang, S., Ota, Y., and Hirota, T. 2001. Optimal thresholding for the automatic recognition of apple fruits. *Amer. Soc. Agr. Eng. Paper No. 01-3133*.

Carew, J. 1969. The prospects for fruit and vegetable mechanization: Horticulture outlook. Fruit and vegetable harvest mechanization. *Rural Manpower Ctr., Michigan State Univ., East Lansing. Rpt. No. 16:79-83*.

Cargill, B.F. 1983. Harvesting high density red tart cherries. *Proc. Intl. Symp. on Fruit, Nut, and Veg. Harvesting Mechanization. Amer. Soc. Agr. Eng. SP-5:195-200*.

Coppock, G.E. 1984. Robotic principles in the selective harvest of Valencia oranges. *Proc. First Intl. Conf. on Robotics and Intelligent Machines in Agr., Amer. Soc. Agr. Eng., Tampa, Fla. ASAE. p. 138-145*.

Davis, V. 1969. Mechanization of fruit and pod vegetables introduction. Fruit and vegetable harvest mechanization. *Rural Manpower Ctr., Michigan State Univ., East Lansing. Rpt. No. 16:205-213*.

Fornes, I., E. Molto, F. Juste, and A. Segura. 1994. Mechanical harvesting of citrus: Evolution of damage produced and fruit behaviour during post-harvest. *EurAg Eng 94. Rpt. N-94-G061*.

Fujiura, T. 1997. Agricultural robots using 3D vision sensor. *Robot. July 1997. 117:32-38*.

Grand D'Esnon, A. 1985. Robotic harvesting of apples. *Proc. Agri-Mation 1:210-214*.

Grand D'Esnon, A., G. Rabatel, R. Pelenc, A. Journeau, and M.J. Aldon. 1987. MAGALI: A self-propelled robot to pick apples. *Amer. Soc. Agr. Eng. Paper No. 87-1037*.

Harrell, R.C., P.D. Adsit, T.A. Pool, and R. Hoffman. 1988. The Florida robotic grove-lab. *Amer. Soc. Agr. Eng. Paper No. 88-1578*.

Ito, N. 1990. Agricultural robots in Japan. *Inst. Electrical and Electronics Eng. Intl. Wkshp. Intelligent Robots and Systems. Ibaraki, Japan 1:249-253*.

Iida, M. and T.F. Burks. 2002. Ultrasonic sensor development for automatic steering control of orchard tractor. *Proc. of the Conf. Automation Technol. for Off-Road Equipment. Amer. Soc. Agr. Eng. Publ. 701P0502:221-229*.

Jimenez, A.R., R. Ceres, and J.L. Pons. 2000. Vision system based on a laser range-finder applied to robotic fruit harvesting. *Machine Vision and Applications 11(6):321-329*.

Juste, F., C. Gracia, E. Molto, R. Ibanez, and S. Castillo. 1988. Fruit bearing zones and physical properties of citrus for mechanical harvesting. *Citriculture. Proc. Sixth Intl. Congr. Middle-East, Tel Aviv, Israel 4:1801-1809*.

Kodagoda, K.R.S., W.S. Wijesoma, and E.K. Teoh. 2002. Fuzzy speed and steering control of an AGV. *Inst. Electrical and Electronics Eng. Trans. on Control Systems Technol. 10(1):112-120*.

Lapushner, D., R. Frankel, and E. Edelman. 1983. Genetical and cultural aspects for mechanical harvested fresh market tomatoes. *Proc. Intl. Symp. on Fruit, Nut, and Veg. Harvesting Mechanization 5(12):404-407*.

Mizushima, A., N. Noguchi, K. Ishii, and H. Terao. 2002. Automatic navigation of the agricultural vehicle by the geomagnetic direction sensor and gyroscope. *Proc. Conf. Automation Technol. for Off-Road Equipment. Amer. Soc. Agr. Eng. Publ. 701P0502:204-211*.

Monselise, S.P. and E.E. Goldschmidt. 1982. Alternate bearing in fruit trees. *Hort. Rev. 4:155-158*.

Morris, J.R. 1983. Effects of mechanical harvesting on the quality of small fruits and grapes. *Proc. Intl. Symp. on Fruit, Nut, and Veg. Harvesting Mechanization 5(12):332-348*.

Nagasaka, Y., N. Umeda, and Y. Kanetai. 2002. National Agr. Res. Center, Japan: Automated rice transplanter with GPS and FOG. *Proc. Conf. Automation Technol. for Off-Road Equipment. ASAE Publ. 701P0502:190-195*.

- Noguchi, N., M. Kise, K. Ishii, and H. Terao. 2002. Field automation using robot tractor. Proc. Conf. Automation Technol. for Off-Road Equipment. ASAE Publ. 701P0502:239-245.
- O'Connor, M., G. Elkaim, Jr., and B. Parkinson. 1995. Kinematic GPS for closed-loop control of form and construction vehicles. Stanford Univ., Stanford, Calif. Paper No. 10NGPS-95.
- Parrish, E.A., Jr., and A.K. Goksel. 1997. Pictorial pattern recognition applied to fruit harvesting. Trans. ASAE 20(5):822-827.
- Peterson, D.L., B.S. Bennedsen, W.C. Anger, and D. Wolford. 1999. A systems approach to robotic bulk harvesting of apples. Trans. of the ASAE 42(4):871-876.
- Plebe, A. and G. Grasso. 2001. Localization of spherical fruits for robotic harvesting. Machine Vision and Applications. 13(2):70-79.
- Pool, T.A. and R.C. Harrell. 1991. An end-effector for robotic removal of citrus from the tree. Trans. ASAE 34(3/4):373-378.
- Qiu, H., Q. Zhang, and J. Reid. 2001. Fuzzy control of electrohydraulic steering systems for agricultural vehicles. Trans. ASAE 44(6):1397-1402.
- Rabatel, G., A. Bourely, F. Sevila, and F. Juste. 1995. Robotic harvesting of citrus: State-of-art and development of the French Spanish Eureka Project. Harvest and Post-harvest Technol. for Fresh Fruits and Veg.: Amer. Soc. Agr. Eng. Proc. Intl. Conf., Guanajunto, Mexico: 232-239.
- Rohrbach, R.P. 1983. Mechanized maintenance of blueberry quality. Proc. Intl. Symp. on Fruit, Nut, and Veg. Harvesting Mechanization Amer. Soc. Agr. Eng. SP-5:134-140.
- Sarig, Y. 1993. Robotics of fruit harvesting: A state-of-the-art review. J. Agr. Eng. Res. 54(4):265-280.
- Schertz, C.E. and G.K. Brown. 1968. Basic consideration in mechanizing citrus harvest. Trans. Amer. Soc. Agr. Eng. 11:343-346.
- Senoo, S., M. Mino, and S. Funabiki. 1992. Steering control of automated guided vehicle for steering energy saving by fuzzy reasoning. Proc. 1992 Inst. Electrical and Electronics Eng. Ind. Applications Soc. Annu. Mtg.:1712-1716.
- Sims, W.L. 1969. Cultural practices for fruit vegetables. Fruit and Vegetable Harvest Mechanization. Rural Manpower Ctr., Michigan State Univ., East Lansing. Rpt. No. 16:225-237.
- Tuttle, E. 1985. Robotic fruit harvester. U.S. Patent No. 4,532,757. U.S. Patent Office, Washington, D.C.
- Wolf, I. and Y. Alper. 1983. Mechanization of paprika harvest. Proc. Intl. Symp. on Fruit, Nut, and Veg. Harvesting Mechanization Amer. Soc. Agr. Eng. SP-5:265-275.
- Zhang, Q., J. Reid, and N. Noguchi. 1999. Automatic guidance control for agricultural tractor using redundant sensor. Soc. Automation Eng. Trans., J. Commercial Vehicles (108):27-31.
- Zocca, A. 1983. Shake harvesting trials with market apples. Proc. Intl. Symp. on Fruit, Nut, and Veg. Harvesting Mechanization 5(12):65-72.